

FLEXISPOT

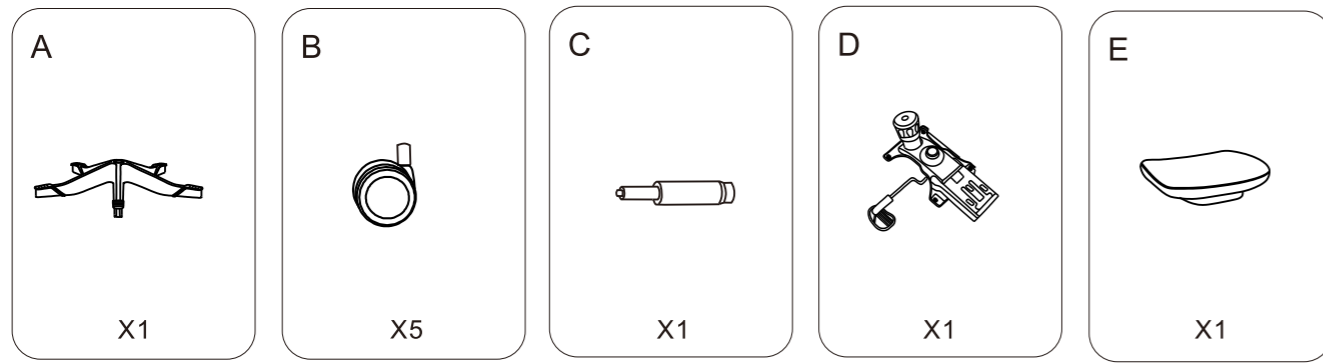

Item No. BS8B/BS8G
Installation Guide

PARTS



Seat Base

Wheel

Gas Lift

Mechanism

Seat

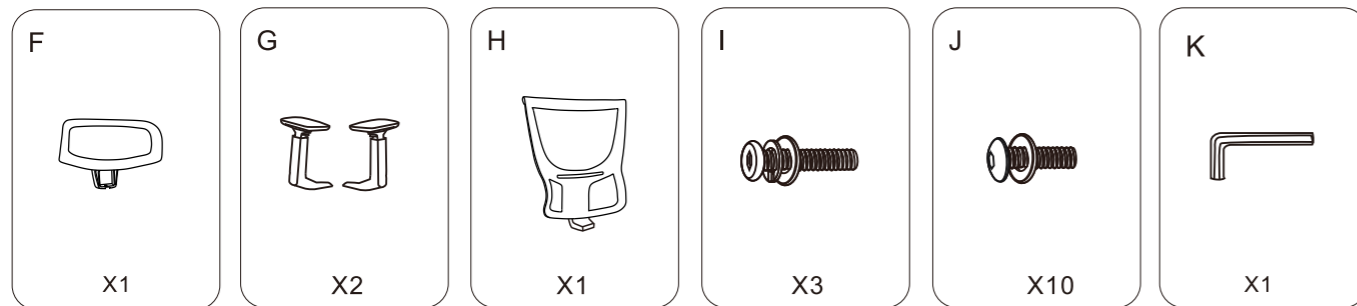

Head Rest

Armrests

Seat Back

M8X20
M8
M8X16X2

M6X40
M6
M6X15X1.5

Wrench

Step 1

Install the five Wheels (B) on Seat Base (A).

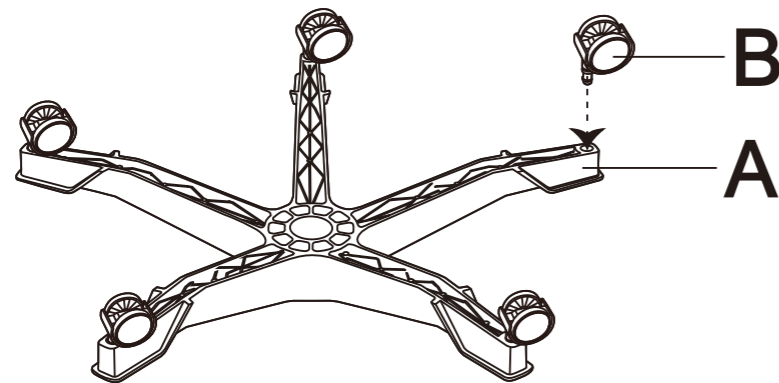

Step 2

Insert Gas Lift (C) to the Base (A).

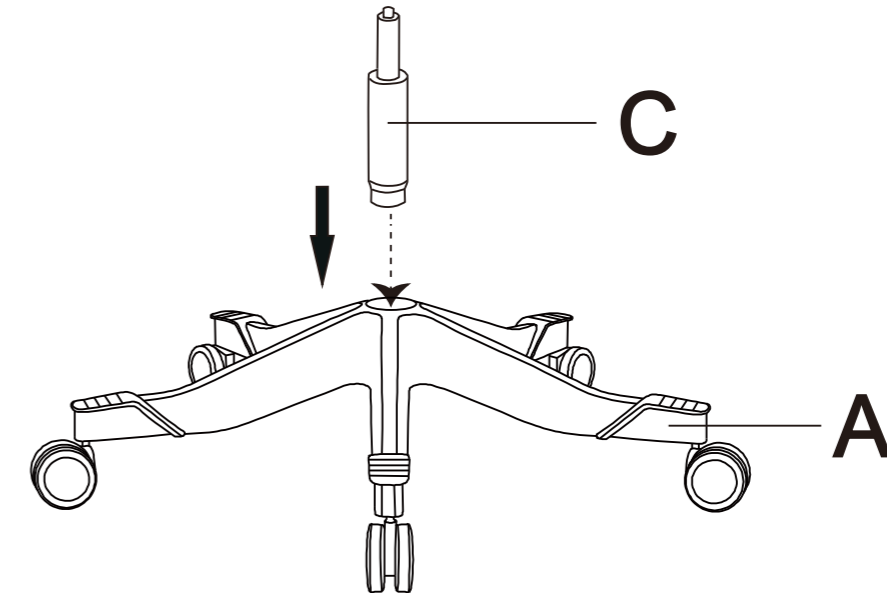

Step 3

Fix Left and Right Armrests (G) on the Seat (E) with screw (J).

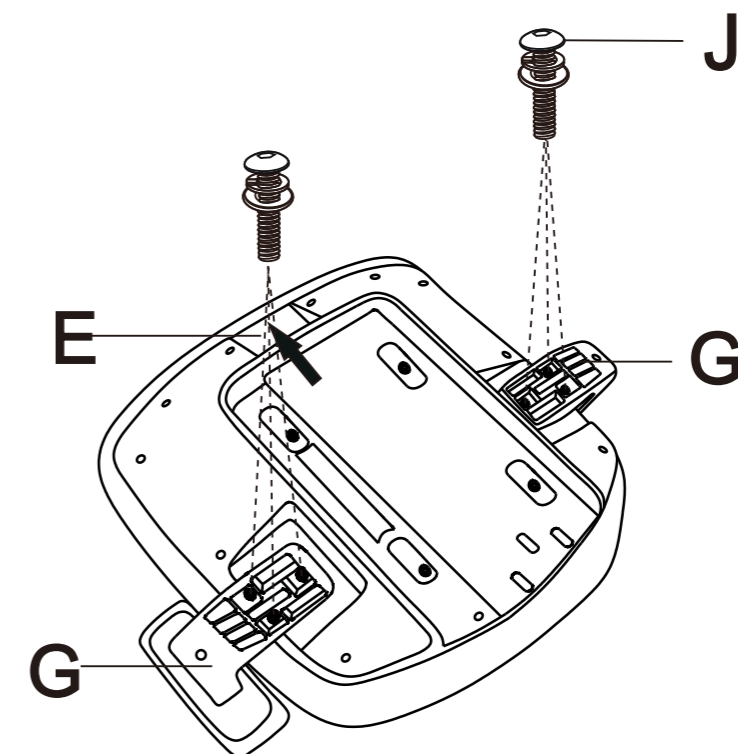

Step 4

Install Mechanism (D) on the Seat (E) with screw (J).

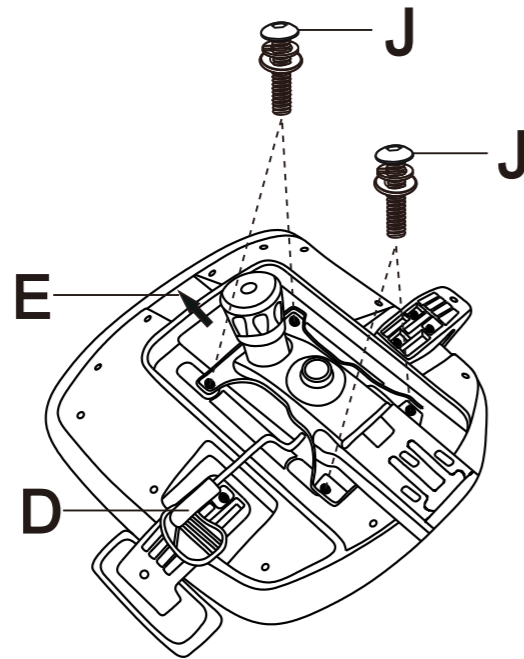

Step 5

Fix Seat Back (H) on the Mechanism (D) with screw (I).

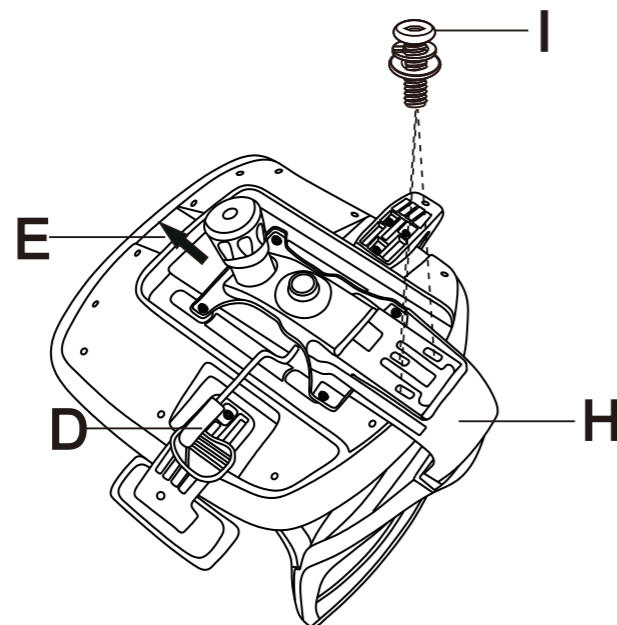

Step 6

Take the screw out of the Headrest (F) first. After the Headrest is stuck on the Seat Back (H), Insert the screw into the Headrest and tighten it with Wrench (K).

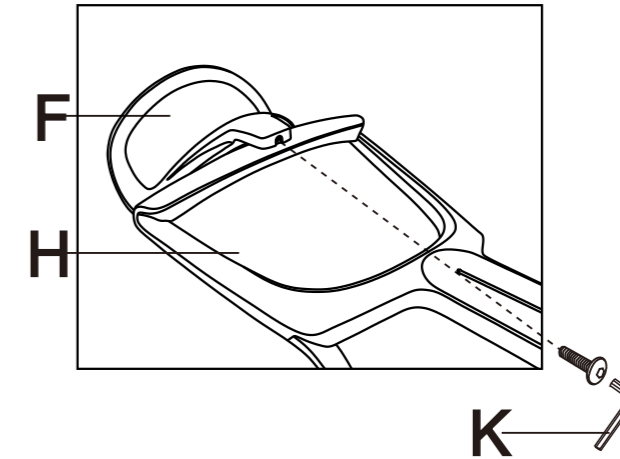

Step 7

Finally, you can enjoy this comfortable chair.

Put the whole Seat Part onto the Gas Lift (C).

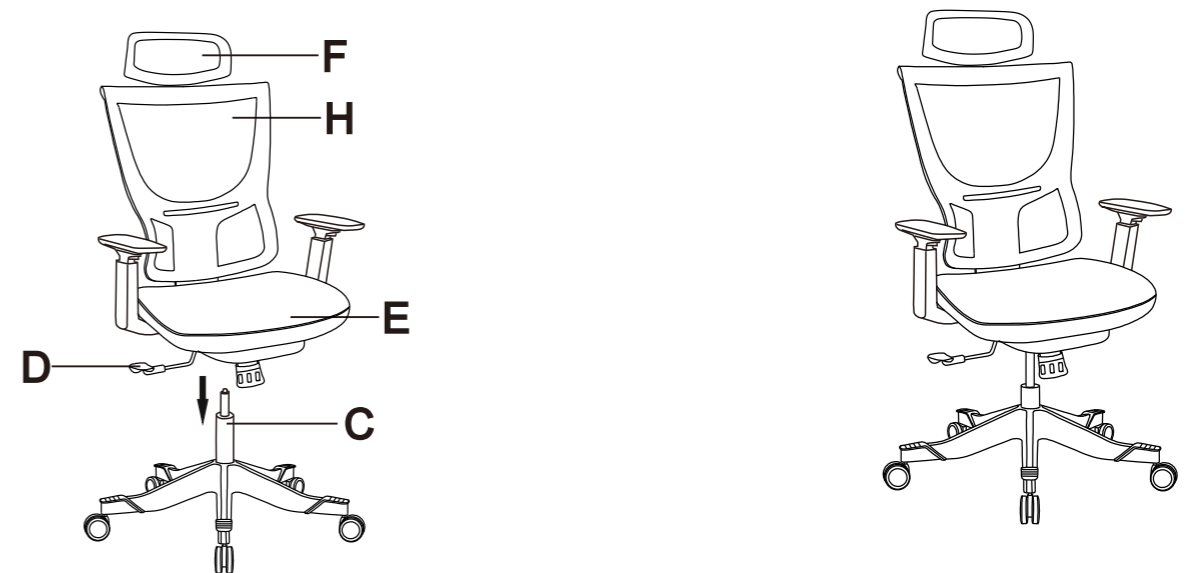

WARNING

FAILURE TO FOLLOW THESE INSTRUCTIONS MAY RESULT IN SERIOUS INJURY

1. THIS PRODUCT IS DESIGNED FOR SEATING ONLY. DO NOT STAND ON THIS PRODUCT. DO NOT USE IT AS A STEP LADDER
2. DO NOT USE THIS PRODUCT UNLESS ALL BOLTS AND PARTS ARE FIRMLY TIGHTENED. AT LEAST WITHIN 3 MONTHS, YOU HAVE TO CHECK ALL THE PARTS FOR SAFETY USE.
3. IF ANY PARTS ARE MISSING, DAMAGED OR WORN, STOP USING THIS PRODUCT, REPAIR THE PRODUCT WITH MANUFACTURER'S SUPPLIED PARTS.
4. DO NOT SIT ON THE ARMREST OF THIS PRODUCT.
5. THIS PRODUCT IS DESIGNED FOR SITTING ONE PERSON AT A TIME.
6. CHILDREN UNDER THE AGE OF 10, PLEASE USE UNDER ADULT SUPERVISION.

WARRANTY

Your satisfaction is our #1 priority here at FlexiSpot. That's why we're pleased to offer a limited warranty that covers defects in material or workmanship on all new FlexiSpot products. This warranty applies solely to the original purchaser and is non-transferable. Only consumers purchasing FlexiSpot products from authorized FlexiSpot retailers or resellers may benefit from our limited warranty.

What is Covered?

FlexiSpot Height Adjustable Desk Frames

All FlexiSpot height adjustable desks purchased on or after 1.Jan,2022 include a limited, non-transferable warranty. We hereby cover all FlexiSpot height adjustable desks for a period of:

FlexiSpot Standing Desk Q8 :

- 10 years for the frame, motor and other mechanisms
- 8 years for the controller, switch, electronics

FlexiSpot Standing Desk E7 & E8 :

- 7 years for the frame, motor and other mechanisms
- 5 years for the controller, switch, electronics

All other standing desks except for E7, E8, Q8 :

- 5 years for the frame, motor and other mechanisms
- 3 years for the controller, switch, electronics

FlexiSpot Sit-Stand Desktop Workstations

All FlexiSpot sit stand desk converters purchased on or after 1.Jan,2022 include a 5-year warranty for the frame, desktop, and a 3-year warranty for the gas spring system and other mechanisms.

FlexiSpot Monitor Mounts

All FlexiSpot monitor mounts purchased on or after 1.Jan,2022 include a 5-year warranty for the arms, gas spring system and mechanisms.

FlexiSpot Chairs

All FlexiSpot chairs purchased on or after 1.Jan,2022 include a 3-5 years warranty. Please refer to the product page.

FlexiSpot Desk Bikes

All FlexiSpot desk bikes purchased on or after 1.Jan,2022 include a 3-year warranty for the frame, and a 1-year warranty for electronics.

FlexiSpot Mini Steppers

All FlexiSpot Mini Steppers purchased on or after 1.Jan,2022 include a 3-year warranty.

What Happens If My Product is Defective?

FlexiSpot will replace (at no charge to you) the defective parts on any of our products when the defect is due to improper workmanship and/or material. If FlexiSpot is unable to provide a replacement product, and repair is not practical or cannot be completed in a timely manner, FlexiSpot may elect to refund the purchase price in exchange for the return of the product.

WARRANTY

Do I Have to Pay Shipping Costs for a Replacement Product?

In the rare event that your FlexiSpot product is defective, we will provide you with a replacement item shipped at no cost to you within The UK mainland. We use DHL to ship replacement products, but expedited shipping is available if you choose to pay the additional expense. If you would like to have a replacement product shipped to an address outside The UK mainland, you will need to pay the shipping costs.

What is Not Covered?

Our limited warranty does not cover any problem caused by:

1. Conditions, malfunctions or damage not resulting from defects in material or workmanship.
2. Conditions, malfunctions or damage resulting from normal wear and tear, improper installation, improper maintenance, misuse, abuse, negligence, accident or alteration.
3. Accessories, connected materials and products, or related products not manufactured by FlexiSpot.
4. Conditions, malfunctions or damage resulting from failure to follow the instructions and guidelines relating to the product's intended use.

Our limited warranty is void if a product is returned with removed, damaged or tampered labels or any alterations (including removal of any component or external cover).

How to File a Claim?

Filing a claim for warranty service is quick and easy. Simply contact customer service via email at info.uk@flexispot.com or toll free at +44 20 3929 3835. Make sure you have your sales receipt or other proof of purchase handy. You will need to provide evidence of the date and place of purchase for your FlexiSpot product.

Disclaimer of Warranties; Limitation of Damages

Except to the extent prohibited by applicable law, all implied warranties (including warranties of merchantability and fitness for a particular Purpose) shall be limited in duration to the duration of this warranty, and FlexiSpot shall not be liable for any incidental, indirect, special, or Consequential damages, including but not limited to loss of profits or Revenue, resulting from any breach of express or implied warranty or Condition, or under any other legal theory, even if flexispot has been advised Of the possibility of such damages. Some jurisdictions do not allow limitations On the duration of an implied warranty or the exclusion or limitation of Special, indirect, incidental or consequential damages, so the above Limitations or exclusions may not apply to you.

Governing Law

This Warranty is governed by the laws of England, without giving effect to any conflict of laws principles that may provide the application of the law of another jurisdiction.